



A Unit of Bhavya Educational Services LLP

सिर्फ मेडिकल PREPARATION का संस्थान

TEST BOOKLET CODE

50

RE-NEET (UG) - 2026

Held on SUNDAY 21st June, 2026

Questions and Answers

Expected cut off marks of **RE-NEET (UG)-2026** (15% All India Quota) : 570 ± 10 [Gen]

Expected cut off marks of **RE-NEET (UG)-2026** (Jharkhand State Quota) : 560 ± 10 [Gen]

IMPORTANT INSTRUCTIONS

1. The test is of **3 hours 15 minutes** duration and the Test Booklet contains 180 multiple choice questions (Four options with a single correct answer) from **Physics, Chemistry** and **Biology (Botany and Zoology)**.
2. Each question carries **4 marks**. For each correct response, the candidate will get **4 marks**. For every wrong response **1 mark** shall be deducted from the total scores. The maximum marks are 720.
3. Use Blue/Black Ball Point Pen only for writing particulars on this page/marking responses on Answer Sheet.
4. On completion of the test, the candidate must hand over the Answer Sheet (ORIGINAL and OFFICE Copy) to the Invigilator before leaving the Room / Hall. The candidates are allowed to take away this Test Booklet with them.
5. The **CODE** for this Booklet is **45**.
6. The candidates should ensure that the Answer Sheet is not folded. Do not make any stray marks on the Answer Sheet. Do not write your Roll No. anywhere else except in the specified space in the Test Booklet/Answer Sheet. Use of white fluid for correction is NOT permissible on the Answer Sheet.
7. Each candidate must show on-demand his/her Admit Card to the Invigilator.
8. No candidate, without special permission of the Centre Superintendent or Invigilator, would leave his/her seat.
09. Use of Electronic/Manual Calculator is prohibited.
10. The candidates will write the Correct Test Booklet Code as given in the Test Booklet / Answer Sheet in the Attendance Sheet.

PHYSICS

01. A particle of mass M moves along a horizontal x axis from $x = 0$ to $x = L$. The coefficient of kinetic friction varies as a function of x as $\mu_k(x) = \mu_0 - \alpha x$, where μ_0, α are constants of appropriate dimensions, m so that $\mu_k(L) = 0$. The total work done by the frictional force during the motion is $n\mu_0 MgL$, where g is the acceleration due to gravity. The value of n is:

- (1) 3 (2) 1
 (3) $\frac{1}{3}$ (4) $\frac{1}{2}$

Ans. (4)

02. The mean free path of molecules in an ideal gas A is half that of another ideal gas B. The diameter of the spherical molecules of gas A is twice the diameter of the molecules of B. If number densities of the gases A and B are n_A and n_B , respectively, then the correct option is:

- (1) $n_A = n_B$ (2) $n_A = 2n_B$
 (3) $n_A = \frac{1}{4}n_B$ (4) $n_A = \frac{1}{2}n_B$

Ans. (4)

03. Two identical inductors are connected in two different configurations P and Q, where a time varying current $I(t)$ is flowing, as shown in the figure. The induced emf between points a and b for configuration P is E_P and that for configuration Q is E_Q . The ratio E_P/E_Q is :
 [Neglect the effect of mutual inductance.]

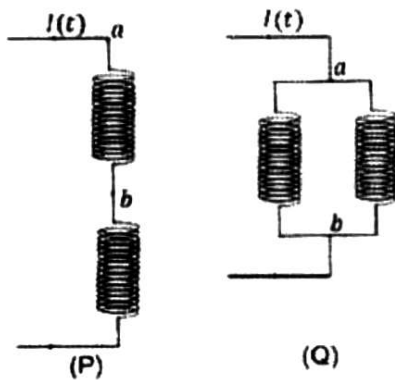

- (1) $1/4$ (2) $1/2$
 (3) 1 (4) 2

Ans. (4)

04. For sound waves, if the number of nod for the 5th harmonic of an open-end pipe is n and that for the 9th harmon of the same pipe with one of its end closed is m , the ratio $\frac{n}{m}$ is :

- (1) $\frac{5}{9}$ (2) $\frac{9}{5}$ (3) 1 (4) $\frac{3}{5}$

Ans. (3)

05. Consider a long solenoid of length l and radius r . If n is the number of turns per unit length and μ_0 is the permeability of free space, the inductance of the solenoid is :

- (1) $\mu_0 \pi n^2 r^2 l$ (2) $\mu_0 n^2 r^2 l$
 (3) $(\mu_0 / 2\pi) n^2 r^2 l$ (4) $2\mu_0 \pi n^2 r^2 l$

Ans. (1)

06. Consider a particle moving along a straight line, whose position as a function of time is given by $s(t) = \alpha t^2 - \beta t + \gamma$, where $\alpha = 1 \text{ ms}^{-2}$, $\beta = 6 \text{ ms}^{-1}$ and $\gamma = 5 \text{ m}$. The average speed of the particle, in ms^{-1} , from $t = 0$ to $t = 6 \text{ s}$ is :

- (1) 12 (2) 6
 (3) 3 (4) 0

Ans. (3)

07. Consider the following nuclear reaction :

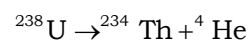

Take masses of ${}^{238}\text{U}$, ${}^{234}\text{Th}$ and 4He as 238.050 u, 234.043 u and 4.003 u, respectively. The Q value for the reaction, in keV, is:

[Given $1 \text{ u} = 931.5 \text{ MeV } c^{-2}$]

- (1) 3726 (2) 3730
 (3) 3736 (4) 3740

Ans. (1)

08. A beam of light falls on a metal surface such that photo-electrons are generated. If power of the light source starts to decrease linearly with time t , then variation of the photocurrent I and magnitude of the stopping potential V with time is best represented by :

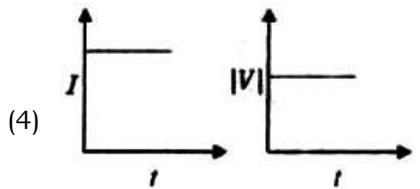
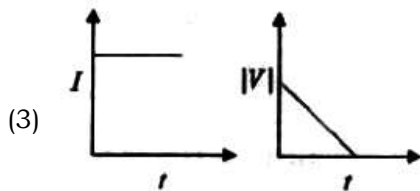
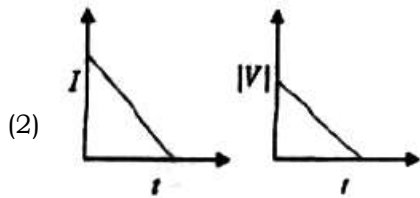
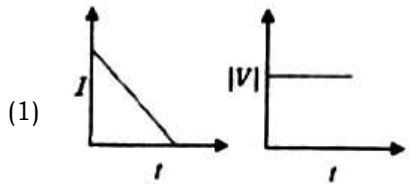

Ans. (1)

09. Three identical capacitors P, Q and S, each of the capacitance C, are connected to a battery of voltage V, as shown in the figure. If the energy stored in the capacitor P and total energy stored in the system are U_p and U_T , respectively, then

the ratio $\frac{U_p}{U_T}$ is :

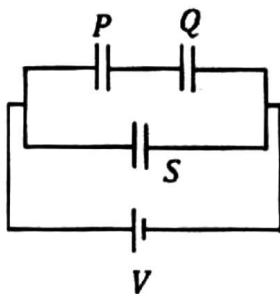

- (1) $2/3$ (2) $1/3$
 (3) $1/2$ (4) $1/6$

Ans. (4)

10. Water flows in a streamline motion through a horizontal pipe of circular cross-section as shown in the figure. The pressure difference of water between P and Q is 15 Nm^{-2} . The area of cross-section at P and Q are 40 cm^2 and 20 cm^2 , respectively. The rate of flow of water through the pipe, in cm^3s^{-1} , is:

[Take density of water = 1000 kg m^{-3}]

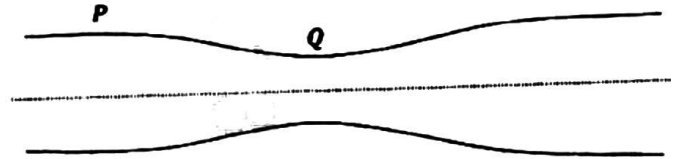

- (1) 100 (2) 200
 (3) 300 (4) 400

Ans. (4)

11. A current I_0 flows through a metallic circular loop of radius r as shown in the figure. Resistance of the segment AB is half that of ADC. Magnitude of magnetic field at the center O of the loop is:

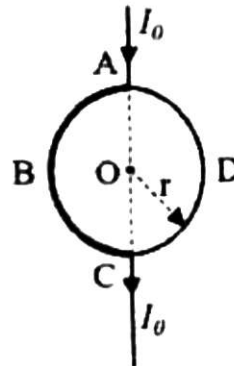

- (1) $\frac{\mu_0 I_0}{12r}$ (2) $\frac{\mu_0 I_0}{4r}$
 (3) $\frac{\mu_0 I_0}{2r}$ (4) $\frac{\mu_0 I_0}{2\pi r}$

Ans. (1)

12. In the measurement of viscosity of liquids using terminal velocity experiment, spherical balls of same radius but having different densities are used. The variation of the terminal velocity (v) with the ratio of density of spherical ball (σ) to density of the liquid (ρ), is best represented by :

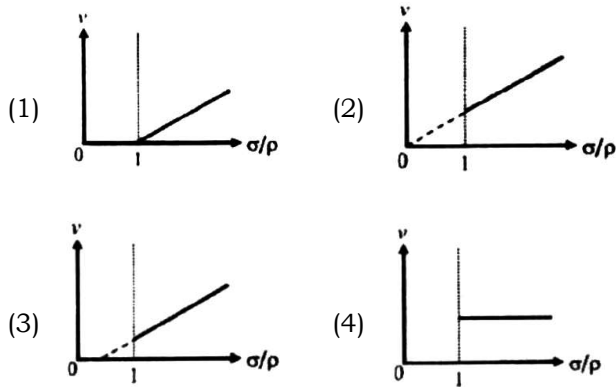

Ans. (1)

13. Two planets P_1 and P_2 with equal mass have radii R_1 and R_2 , respectively where $R_2 = \frac{R_1}{2}$. The escape speeds of P_1 and P_2 are v_1 and v_2 , respectively. Then $\frac{v_2}{v_1}$ is :

- (1) $\frac{1}{\sqrt{2}}$ (2) 1
(3) $\sqrt{2}$ (4) 2

Ans. (3)

14. In a solar system, the time-period of revolution of a planet tracing a circular orbit of radius R is proportional to :

- (1) $R^{1/2}$ (2) $R^{3/2}$
(3) R^2 (4) R^3

Ans. (2)

15. Two infinitely long parallel conducting wires A and B carry currents I and $2I$, respectively, in the same direction. The wire A has uniform mass per unit length λ and lies on an insulated floor. The wire B is kept fixed at a height h above the floor. The minimum magnitude of h so that the wire A does not rise from the floor is :

[g is the acceleration due to gravity and μ_0 is the permeability of free space.]

- (1) $\frac{\mu_0 I^2}{2\pi\lambda g}$ (2) $\frac{\mu_0 I^2}{\pi\lambda g}$
(3) $\frac{2\mu_0 I^2}{\pi\lambda g}$ (4) $\frac{4\mu_0 I^2}{\pi\lambda g}$

Ans. (2)

16. An ideal Zener diode with breakdown voltage of -3 V is reverse biased with a negative input voltage $V = -5$ V. The magnitude of voltage difference between points B and A is:

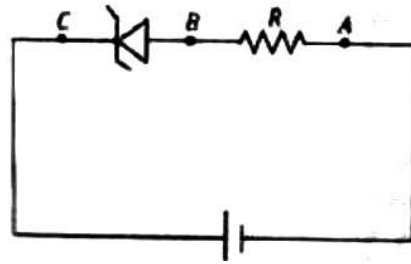

- (1) 3V (2) 2 V
(3) 1 V (4) 0 V

Ans. (2)

17. In an adiabatic expansion, the temperature of one mole of an ideal monatomic gas ($\gamma = 5/3$) decreases from 60K to 50K. The work done by the gas in the process is:

(Take the universal gas constant as $R = 8.3$ J mol⁻¹ K⁻¹)

- (1) 41.5 J (2) 83 J
(3) 124.5 J (4) 166 J

Ans. (3)

18. A ray of light with wavelength λ is incident on three different photoelectric cells namely 1, 2 and 3. The threshold wavelength of these photoelectric cells are λ_1, λ_2 and λ_3 respectively and the magnitude of stopping potentials of these cells are V_1, V_2 and V_3 respectively. The relation between λ and threshold wavelengths are $\lambda_1 < \lambda, \lambda_2 > \lambda$ and $\lambda_3 \gg \lambda$. The correct option is :

- (1) $V_1 = 0, V_2 < V_3$ (2) $V_1 = 0, V_2 > V_3$
(3) $V_1 > V_2, V_3 = 0$ (4) $V_1 < V_2, V_3 = 0$

Ans. (1)

19. A photon and an electron, each of 20eV energy, move in free space. The ratio of linear momentum

of electron p_e to that of photon p_{ph} , $\frac{p_e}{p_{ph}}$ is :

(Take speed of light = 3×10^8 ms⁻¹ charge of electron = -1.6×10^{-19} C and mass of electron = 9×10^{-31} kg)

- (1) $\frac{2}{450}$ (2) $\frac{1}{250}$
 (3) 225 (4) 275

Ans. (3)

20. Which of the following measurements require 'index correction'?

- (1) Measured of resistance of a wire using meter bridge
 (2) Measurement of gravitational acceleration using simple pendulum
 (3) Measurement of focal length of lenses using optical bench
 (4) Measurement of speed of sound using resonance tube

Ans. (3)

21. A unit positive point charge is taken slowly through an infinitesimally thin tube that is inside a charged dielectric sphere of radius R , having uniform positive charge density ρ , as shown in the figure. The initial and final positions of the charge are marked by A and B at distances $2R$ and $3R$ respectively, from the centre of the sphere. In this process, the magnitude of the total work done on the point

charge is $\frac{\rho R^2}{n\epsilon_0}$. The value of n is

(ϵ_0 is the permittivity of vacuum)

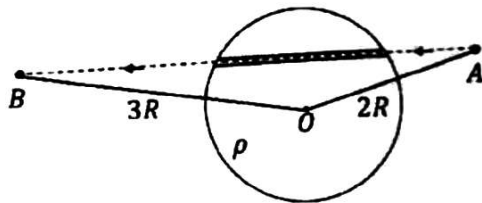

- (1) 2 (2) 6
 (3) 9 (4) 18

Ans. (4)

22. Consider three media P, Q and R with refractive indices 1, 1.25, and 1.5, respectively. The medium Q having a thickness of 5 cm is placed between extended media P and R as shown in the figure. An object O is placed at the center of medium Q. If viewed from medium P near the normal direction, the apparent depth of O is h_1 . For similar observation from medium R, the apparent depth is h_2 . The value of $|h_1 - h_2|$, in

cm, is

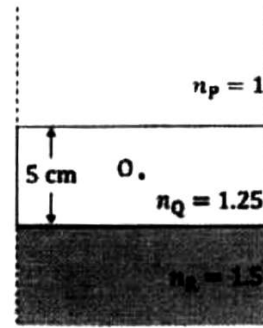

- (1) 0 (2) 1
 (3) 2 (4) 3

Ans. (2)

23. Frictionless circular wire of unit radius is fixed on the horizontal plane. Two point particles of unit mass start moving simultaneously from point A ($\theta = \frac{\pi}{2}$) with identical uniform angular speeds in opposite directions, and meet again at point B ($\theta = -\frac{\pi}{2}$). During this time, which of the following figures schematically represent the magnitude of the total linear momentum P of the system, as a function of θ

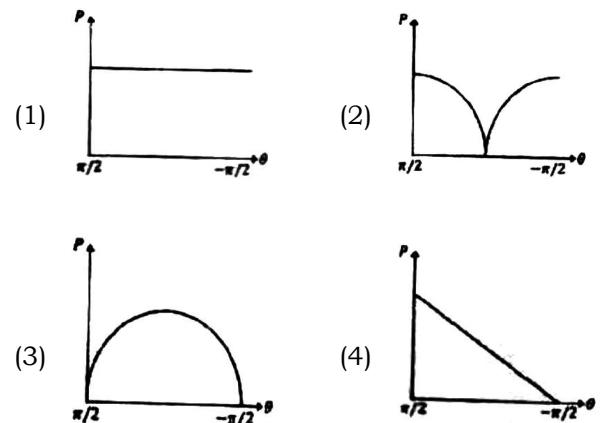
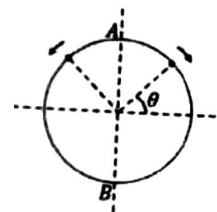

Ans. (3)

24. The temperature of a metallic sphere of radius R is increased by a small amount ΔT . If the linear coefficient of thermal expansion of the metal is α , the approximate increase in the volume of the sphere is

- (1) $2\pi R^3 \alpha \Delta T$ (2) $3\pi R^3 \alpha \Delta T$
 (3) $4\pi R^3 \alpha \Delta T$ (4) $6\pi R^3 \alpha \Delta T$

Ans. (3)

25. A cylindrical cork of uniform density floats in a liquid of density ρ_1 . If the cork is depressed slightly and released, it oscillates harmonically with time period T . If the same cork floats in another liquid of density ρ_2 , then the similar oscillation has time period $2T$. The value of ρ_2 / ρ_1 is:

- (1) 4 (2) 2 (3) 1/2 (4) 1/4

Ans. (4)

26. One main scale division of a Vernier calliper is equal to 1 mm and the number of divisions on the Vernier scale is 10. When both the jaws touch each other, the Vernier scale shifts to the left of zero of the main scale in such a way that 4th vernier division coincides with a division of the main scale. If this Vernier calliper measures the length of a wire to be 1 cm, the actual length of the wire is :

- (1) 0.50 cm (2) 0.96 cm
 (3) 1.00 cm (4) 1.04 cm

Ans. BONUS

27. A solid sphere A of radius R and mass M is attached at a point to a smaller solid sphere B of radius $r < R$ and mass $m < M$. Assume that the line joining their centres lies along the horizontal. The moment of inertia of the system calculated about a vertical axis passing through the centre of A is I_A and that calculated about a vertical axis passing through the centre of B is I_B . The difference $I_A - I_B$ is :

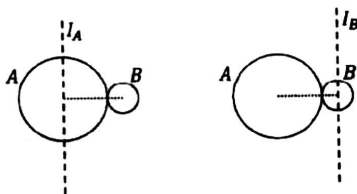

- (1) $(M - m)(R + r)^2$ (2) $(m - M)(R + r)^2$
 (3) $(m - M)(R - r)^2$ (4) 0

Ans. (2)

28. Consider a spring-mass simple harmonic oscillator in one dimension. The mass of the particle is m kg and the spring constant is k Nm^{-1} . At a given instant, the extension of the spring is x meter and the speed of the particle is v ms^{-1} . On the $x - v$ plane, if the graph of v as a function of x is a circle, then the correct option is:

- (1) $k = \frac{1}{m}$ (2) $k = m$
 (3) $k = m^2$ (4) $k = \sqrt{m}$

Ans. (2)

29. The lens combination as shown in the figure, consists of two lenses, L_1 and L_2 , of the focal lengths $+10$ cm and -10 cm, respectively. The position of the image formed is :

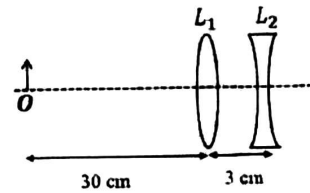

- (1) 20 cm to the left of the concave lens
 (2) 60 cm to the left of the concave lens
 (3) 30 cm to the right of the concave lens
 (4) 60 cm to the right of the concave lens

Ans. (2)

30. An ac voltage $V = 220 \sin(2 \times 10^3 t)$ Volt is applied to a series LCR circuit. Then the current amplitude in this circuit is:

(Given: $L = 10$ mH, $C = 25 \mu\text{F}$, $R = 100 \Omega$)

- (1) 2.2 A (2) 5.5 A
 (3) 11.0 A (4) 22.0 A

Ans. (1)

31. A thin horizontal disc is rotating about a vertical axis passing through its fixed centre O. Its angular momentum is L_A and L_B computed about points A and B, respectively, with $OB = 2 \times OA$.

The value of $\frac{L_A}{L_B}$ is :

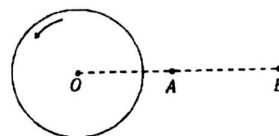

- (1) $\frac{1}{4}$ (2) $\frac{1}{2}$ (3) 1 (4) 2

Ans. (3)

32. A conducting loop of finite resistance lies on the x- y plane. There is a constant magnetic field in the z direction. The area of the loop varies with time t, as $A = A(1 + \sin t)$ in appropriate units. The figure that correctly indicates the qualitative behaviour of the power P dissipated in the loop as a function of time is:

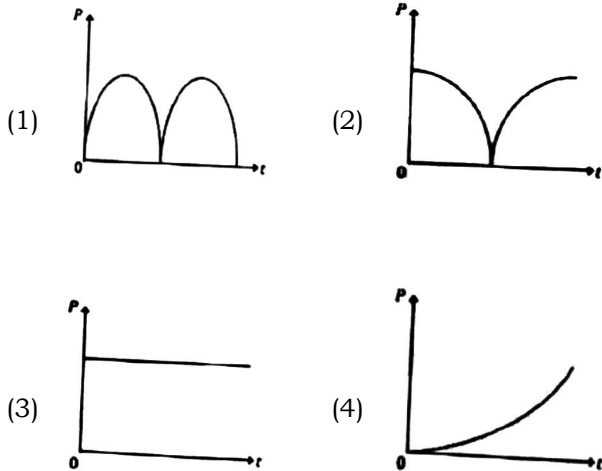

Ans. (2)

33. A point charge Q is placed inside a cavity within a solid isolated conducting sphere. Consider points A, B and C as shown in the figure, where the magnitudes of the electric fields are E_A , E_B and E_C , respectively. The points B and C are at the same distance from the center of the solid sphere. The correct option is :

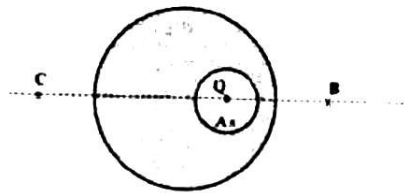

- (1) $E_A = 0, E_B = E_C$ (2) $E_A \neq 0, E_B = E_C$
 (3) $E_A = 0, E_B > E_C$ (4) $E_A \neq 0, E_B < E_C$

Ans. (2)

34. Consider a fixed uniformly charged insulating sphere with radius R and total charge +Q. A point charge -q ($q \ll Q$) with mass m is released from rest at a distance of 3R from the centre of the charged sphere. When the point charge reaches the surface of the sphere, its speed is:

(ϵ_0 is the permittivity of vacuum, neglect gravitational forces).

- (1) $\sqrt{\frac{3Qq}{4\pi\epsilon_0 mR}}$ (2) $\sqrt{\frac{2Qq}{3\pi\epsilon_0 mR}}$
 (3) $\sqrt{\frac{Qq}{3\pi\epsilon_0 mR}}$ (4) $\sqrt{\frac{Qq}{4\pi\epsilon_0 mR}}$

Ans. (3)

35. In Geiger-Marsden experiment, the number of scattered α -particles $N(\theta)$ is plotted as a function of scattering angle θ . Which of the following options represents the correct plot ?

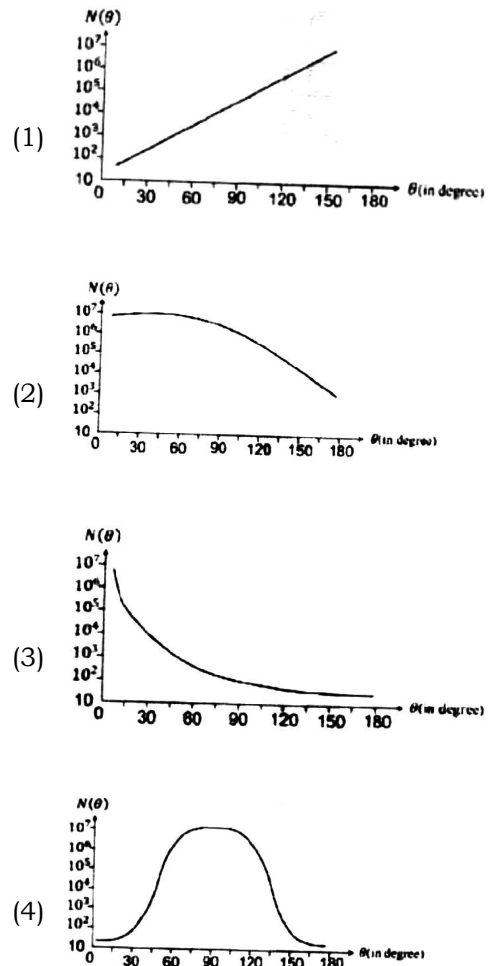

Ans. (3)

36. Consider two circuits, (A) and (B), each having two resistors. One of them has a positive temperature coefficient of resistance, $+\alpha$, while the other one has a negative temperature of coefficient, $-\alpha$, as shown in the figure. The current through these circuits are denoted by I_A and I_B . At initial temperature, the resistance of the two resistors is R_0 . As the temperature is increased, the correct option that describes the variation of current in these circuits is:

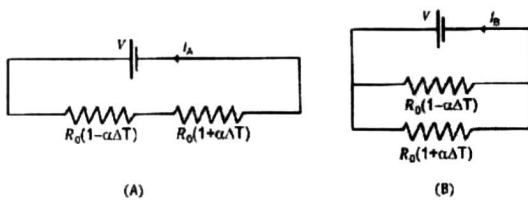

- (1) I_A remains constant while I_B increases
- (2) I_A decreases while I_B increases
- (3) I_A increases while I_B decreases
- (4) both I_A and I_B remain constant

Ans. (1)

37. Consider that σ_s , k_B , b represent Stefan-Boltzmann constant, Boltzmann constant and Wien's displacement law constant, respectively.

The dimension of $\sigma_s k_B^{-1} b$ is :

- (1) $L^{-1}T^{-1}K^{-2}$ (2) $L^{-1}K^{-2}$
- (3) $L^{-1}T^{-1}K^{-3}$ (4) $[L^{-1}T^{-1}K^{-4}]$

Ans. (1)

38. An electromagnetic wave travelling in a lossless dielectric medium having a dielectric constant, $\epsilon_r = 9$, has the electric field,

$E_x = E_0 (kz - 2\pi \times 10^6 t) \text{ Vm}^{-1}$ where E_0 is the amplitude and k is the wave vector. Among the following options, the incorrect choice is :

- (1) The speed of the electromagnetic wave inside the medium is 10^8 ms^{-1}
- (2) The wavelength of the electromagnetic wave inside the medium is 300 m
- (3) The magnetic field is given by the relation

$$B_y = \frac{B_0}{v} \sin(kz - 2\pi \times 10^6 t)$$

- (4) The direction of propagation of the electromagnetic wave is along +z

Ans. (2 & 3)

39. One mole of an ideal monatomic gas undergoes a cyclic process as shown in the figure. The total heat supplied to the gas is

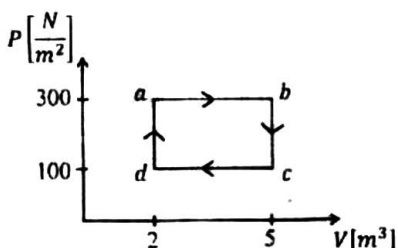

- (1) 400 J (2) 500 J
- (3) 600 J (4) 800 J

Ans. (3)

40. Consider that an electron is revolving in an excited state of Hydrogen atom with velocity $\sqrt{25.6} \times 10^5 \text{ ms}^{-1}$. The radius of the orbit is $x \times 10^{-9} \text{ m}$. The value of x is:

[Take the mass of electron to be $9.1 \times 10^{-31} \text{ kg}$, charge of electron

$$= -1.6 \times 10^{-19} \text{ C and } \frac{1}{4\pi \epsilon_0} = 9 \times 10^9 \text{ N m}^2 \text{ C}^{-2}]$$

- (1) 4 (2) 3
- (3) 2 (4) 1

Ans. (4)

41. A car travels on a circular racetrack of radius 50 m, which is banked at an angle θ . If the car travels at a speed 10 ms^{-1} , then the wear and tear on its tyres is minimum. Taking the acceleration due to gravity to be 10 ms^{-2} , the value of θ is :

- (1) $\tan^{-1}\left(\frac{1}{5}\right)$ (2) $\tan^{-1}\left(\frac{2}{5}\right)$
- (3) $\tan^{-1}(\sqrt{3}/2)$ (4) $\tan^{-1}(2/\sqrt{3})$

Ans. (1)

42. Three identical p-n junction diodes D_1 , D_2 and D_3 are connected across a battery as shown in the figure. If the width of the depletion regions of D_1 , D_2 and D_3 are W_1 , W_2 and W_3 , respectively, then the correct option is :

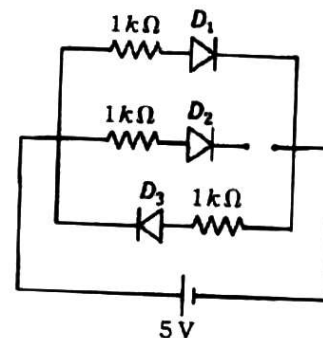

- (1) $W_1 > W_2 > W_3$ (2) $W_3 = W_1 > W_2$
- (3) $W_3 > W_2 > W_1$ (4) $W_2 > W_1 = W_3$

Ans. (3)

43. The following table presents the part of the electromagnetic spectrum and their corresponding major applications.

Part of the electromagnetic spectrum		Applications	
P	Microwave	I	For purifying the water
Q	UV rays	II	For warming the food
R	Gamma rays	III	For AM and FM communication systems
S	Radio wave	IV	For treating the Cancer cells

The correct option is :

- (1) P-I, Q-II, R-III, S-IV
- (2) P-I, Q-IV, R-II, S-III
- (3) P-II, Q-I, R-IV, S-III
- (4) P-II, Q-IV, R-III, S-I

Ans. (3)

44. Bob B of mass m at rest is hanging vertically from the ceiling via a massless string of length 10 m, as shown in the figure. Point mass A of mass m travelling horizontally with speed 10 ms^{-1} hits bob B elastically. The bob B rises h meter after the collision. Taking the acceleration due to gravity $g=10 \text{ ms}^{-2}$ and neglecting the size of the bob, the value of h is:

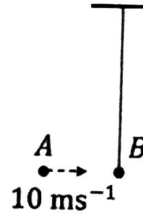

- (1) 8
- (2) 7
- (3) 5
- (4) 2.5

Ans. (3)

45. An ideal gas is made of polyatomic molecules. Each of the molecules has three translational, three rotational and f number of vibrational modes. If the ratio of heat capacities C_p/C_v of the gas is $8/7$, then the value of f is:

- (1) 4
- (2) 3
- (3) 2
- (4) 1

Ans. (1)

CHEMISTRY

46. For the following reaction sequence, choose the correct option

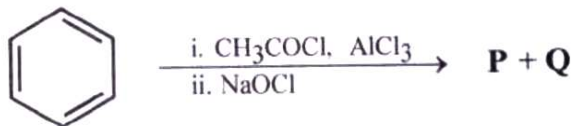

- (1) If P is the sodium salt of a carboxylic acid, Q is a primary alcohol.
- (2) P and Q are aromatic compounds.
- (3) If P gives a carboxylic acid on acidification, Q gives a poisonous gas on exposure to air and light.
- (4) Both P and Q are carbonyl compounds.

Ans. (3)

47. Given below are two statements:

Statement-I : $[\text{Fe}(\text{ox})_3]^{3-}$ is chiral.

Statement-II: $\text{trans}[\text{Cr}(\text{H}_2\text{O})_2(\text{ox})_2]^-$ is chiral.

(Given: $\text{oxH}_2 = \text{HOOC}-\text{COOH}$)

In light of the above statements, choose the most appropriate answer from the options given below:

- (1) Both Statement-I and Statement-II are correct.
- (2) Both Statement-I and Statement-II are incorrect.
- (3) Statement-I is correct but Statement-II is incorrect.
- (4) Statement-I is incorrect but Statement-II is correct.

Ans. (3)

48. The following carbocation is stabilized by the interaction of the empty p orbital with

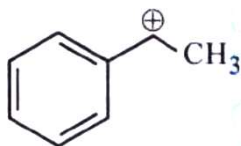

- (1) filled σ and filled π orbitals
- (2) empty σ and empty π^* orbitals
- (3) empty σ^* and filled π orbitals
- (4) empty σ^* and empty π^* orbitals

Ans. (1)

49. In potash alum, the ratio of K^+ and ions is SO_4^{2-}

- (1) 1:2
- (2) 2:1
- (3) 2:3
- (4) 3:2

Ans. (1)

50. The correct statement about peptides and proteins is

- (1) Tertiary structure of proteins has two or more polypeptide subunits.
- (2) Only the proteins having a quaternary structure are biologically active.
- (3) In β -pleated sheet structures, peptide chains are held together by intermolecular hydrogen bonds.
- (4) In α -helices, the polypeptide chain is twisted into a left-handed screw (helix) through intramolecular hydrogen bonds.

Ans. (3)

51. The numbers 17.0145 and 21.0235 were rounded to three figures after the decimal point. The resulting numbers, respectively, are

- (1) 17.014 and 21.023
- (2) 17.015 and 21.023
- (3) 17.014 and 21.024
- (4) 17.015 and 21.024

Ans. (3)

52. The correct order of solubility of the given salts in water at 298 K is

Salt	K_{sp} at 298 K
AgBr	5.0×10^{-13}
$\text{Zn}(\text{OH})_2$	1.0×10^{-15}
Hg_2Cl_2	1.3×10^{-18}

- (1) $\text{Hg}_2\text{Cl}_2 > \text{Zn}(\text{OH})_2 > \text{AgBr}$
- (2) $\text{AgBr} > \text{Zn}(\text{OH})_2 > \text{Hg}_2\text{Cl}_2$
- (3) $\text{Hg}_2\text{Cl}_2 > \text{AgBr} > \text{Zn}(\text{OH})_2$
- (4) $\text{Zn}(\text{OH})_2 > \text{AgBr} > \text{Hg}_2\text{Cl}_2$

Ans. (4)

53. Among the following options, the correct trend in the electron gain enthalpy is

- (1) $\text{F} > \text{Cl} > \text{Br} > \text{I}$
- (2) $\text{Br} > \text{Cl} > \text{F} > \text{I}$
- (3) $\text{Cl} > \text{F} > \text{Br} > \text{I}$
- (4) $\text{I} > \text{Br} > \text{Cl} > \text{F}$

Ans. (3)

54. **Assertion A:** For an ideal solution formed by mixing liquids P and Q, $\Delta_{\text{mix}} H = 0$ and $\Delta_{\text{mix}} V = 0$

Reason R: No interactions occur between P and Q

In the light of the above statements, choose the most appropriate answer from the options given below.

- (1) Both A and R are correct and R is the correct explanation of A
- (2) Both A and R are correct but R is NOT the correct explanation of A
- (3) A is correct but R is not correct
- (4) A is not correct but R is correct

Ans. (3)

55. The amino acid that gives a red-blood colour on treating its sodium fusion extract with sodium nitroprusside is

- (1) leucine
- (2) threonine
- (3) methionine
- (4) serine

Ans. (3)

56. The standard electrode potential (E°) for the half-cell reaction $\text{Fe}^{3+} + e^- \rightarrow \text{Fe}^{2+}$ at 298 K is

(Given: $E^\circ(\text{Fe}^{3+}/\text{Fe}) = -0.04 \text{ V}$ and $E^\circ(\text{Fe}^{2+}/\text{Fe}) = -0.44 \text{ V}$ at 298 K)

- (1) +0.40 V
- (2) +0.76 V
- (3) -0.48 V
- (4) +0.92 V

Ans. (2)

57. In an acidic medium, 10 mL of 0.25 M oxalic acid is titrated with KMnO_4 solution. If the volume of KMnO_4 solution required to reach end point is 10 mL, the strength of the KMnO_4 solution is

- (1) 0.10 M
- (2) 0.20M
- (3) 0.25 M
- (4) 0.15 M

Ans. (1)

58. According to crystal field theory, the correct order of ligands with respect to their decreasing order of field strength is

- (1) $\text{CO} > \text{NH}_3 > \text{H}_2\text{O} > \text{Cl}^-$
- (2) $\text{CO} > \text{HO} > \text{NH}_3 > \text{Cl}^-$
- (3) $\text{Cl}^- > \text{H}_2\text{O} > \text{NH}_3 > \text{CO}$
- (4) $\text{Cl}^- > \text{NH}_3 > \text{H}_2\text{O} > \text{CO}$

Ans. (1)

59. Two moles of an ideal gas undergo free expansion from 10 L to 100 L at 300 K. The values of ΔS_{system} and $\Delta S_{\text{surroundings}}$ are

(R is universal gas constant)

(1) $\Delta S_{\text{system}} = 0$; $\Delta S_{\text{surroundings}} = 0$

(2) $\Delta S_{\text{system}} = 4.606 R$;

$\Delta S_{\text{surrounding}} = -4.606 R$

(3) $\Delta S_{\text{system}} = 0$; $\Delta S_{\text{surroundings}} = 4.606 R$

(4) $\Delta S_{\text{system}} = 4.606 R$; $\Delta S_{\text{surroundings}} = 0$

Ans. (4)

60. $2A \xrightarrow{k} B$ is a zero-order reaction, where $k = 1.0 \text{ mol L}^{-1} \text{ min}^{-1}$. If the initial concentration of A is 2 M, then the time taken to complete 75% of the reaction will be

- (1) 1.5 min
- (2) 0.75 min
- (3) 1.0 min
- (4) 2.0 min

Ans. (2)

61. Given below are two statements: One is labelled as Assertion A and the other is labelled as Reason R.

Assertion A: Generally, 3d transition metals have high melting points.

Reason R: Involvement of 3d-electrons in addition to 4s-electrons in the interatomic metallic bonding.

In light of the above statements, choose the most appropriate answer from the options given below:

- (1) Both A and R are correct and R is the correct explanation of A.
- (2) Both A and R are correct and R is NOT the correct explanation of A.
- (3) A is correct but R is not correct.
- (4) A is not correct but R is correct.

Ans. (1)

62. For a salt XY, which is a strong electrolyte, the plot of Λ_m versus \sqrt{c} has a slope of $-90.0 \text{ S cm}^2 \text{ mol}^{-3/2} \text{ L}^{1/2}$ at 298 K. At 0.01 M concentration of XY, the value of Λ_m is $145.0 \text{ S cm}^2 \text{ mol}^{-1}$. The limiting molar conductivity of Y-ion ($\lambda_{Y^-}^0$, in $\text{S cm}^2 \text{ mol}^{-1}$) at 298 K will be

(Given: $\lambda_{X^+}^0 = 74.0 \text{ S cm}^2 \text{ mol}^{-1}$)

- (1) 80.0 (2) 100.0
 (3) 90.0 (4) 76.0

Ans. (1)

63. The amount of carbon dioxide evolved upon complete combustion of 116 g of n-butane is (Given: atomic mass in amu H = 1, C = 12 and O = 16)

- (1) 352 g (2) 322 g
 (3) 176 g (4) 362 g

Ans. (1)

64. For an elementary chemical reaction, the Arrhenius plot is given below.

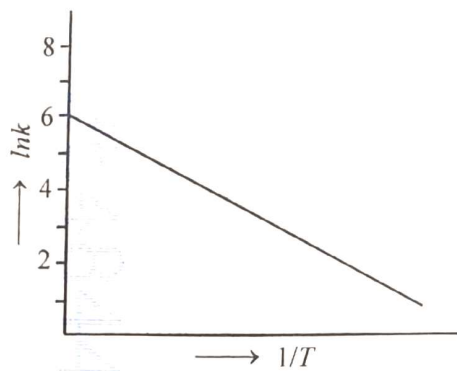

If the energy of activation is 6.64 kJ mol^{-1} and $R = 8.3 \text{ JK}^{-1} \text{ mol}^{-1}$, the temperature at which the rate constant becomes $e^2 \text{ min}^{-1}$, is

- (1) 125 K (2) 150 K
 (3) 200 K (4) 250 K

Ans. (3)

65. Given below are two statements:

Statement-I: Heating NaCl with concentrated H_2SO_4 and MnO results in oxidation of Mn.

Statement-II: Heating NaI with concentrated H_2SO_4 and MnO_2 results in reduction of Mn.

In light of the above statements, choose the most appropriate answer from the options given below:

- (1) Both Statement-I and Statement-II are correct.
 (2) Both Statement-I and Statement-II are incorrect.
 (3) Statement-I is correct but Statement-II is incorrect.
 (4) Statement-I is incorrect but Statement-II is correct.

Ans. (4)

66. Among the species given below, the spin-only magnetic moment is highest for

(Given: Atomic number of Ti = 22, Mn = 25, Fe = 26 and Co = 27)

- (1) $[\text{Mn}(\text{CN})_6]^{3-}$ (2) $[\text{Fe}(\text{CN})_6]^{3-}$
 (3) $[\text{Co}(\text{NH}_3)_6]^{3+}$ (4) $[\text{Ti}(\text{H}_2\text{O})_6]^{3+}$

Ans. (1)

67. The lanthanide ion having four unpaired electrons is

(Given: Atomic numbers of Ce = 58, Nd = 60, Tb = 65 and Ho = 67)

- (1) Nd^{3+} (2) Ce^{3+}
 (3) Tb^{3+} (4) Ho^{3+}

Ans. (4)

68. The formula of tetraammineaquachloridocobalt(III) chloride is

- (1) $[\text{Co}(\text{NH}_3)_4\text{Cl}_2] \times \text{H}_2\text{O}$
 (2) $[\text{Co}(\text{NH}_3)_4]\text{Cl}_3 \times \text{H}_2\text{O}$
 (3) $[\text{Co}(\text{NH}_3)_4(\text{H}_2\text{O})\text{Cl}]\text{Cl}$
 (4) $[\text{Co}(\text{NH}_3)_4(\text{H}_2\text{O})\text{Cl}]\text{Cl}_2$

Ans. (4)

69. Consider the reversible processes for 1.0 mol of an ideal gas as shown in the figure

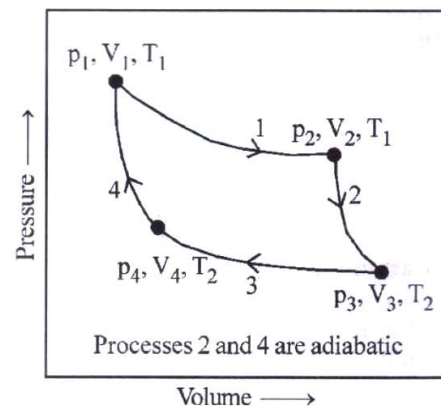

w_1 , w_2 , w_3 and w_4 represent work done (in calories) in the processes 1, 2, 3 and 4, respectively; ΔU_2 and ΔU_4 are changes in the internal energy for the processes 2 and 4, respectively.

[use $R = 2 \text{ cal K}^{-1} \text{ mol}^{-1}$]

The correct option is

$$(1) w_1 + w_3 = -2R_1 \ln \frac{V_2}{V_1} - 2T_2 \ln \frac{V_4}{V_3}$$

$$(2) w_2 + w_4 = \Delta U_2 - \Delta U_4$$

$$(3) w_1 + w_2 = 2R_1 \ln \frac{V_2}{V_1}$$

$$(4) w_1 + w_2 + w_3 + w_4 = 0$$

Ans. (1)

70. Given below are two statements: One is labelled as Assertion A and the other is labelled as Reason R.

Assertion A: The first ionization enthalpy of O is lower than that of N and F.

Reason R: The loss of an electron from O leads to stable half-filled p orbital.

In light of the above statements, choose the most appropriate answer from the options given below:

- (1) Both A and R are correct and R is the correct explanation of A.
- (2) Both A and R are correct and R is NOT the correct explanation of A.
- (3) A is correct but R is not correct.
- (4) A is not correct but R is correct.

Ans. (1)

71. Consider the following statements about the solutions formed by mixing two liquid.

A. An ideal solution thus formed obeys Raoult's law throughout the composition range.

B. Mixture of chloroform and acetone shows negative deviation from Raoult's law.

C. Mixture of aniline and phenol shows positive deviation from Raoult's law.

- (1) A and B only
- (2) B and C only
- (3) A only
- (4) A and C only

Ans. (1)

72. One of the products formed in the following reaction is

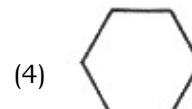
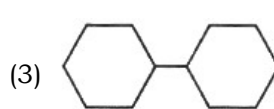
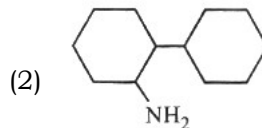
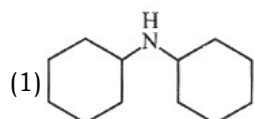
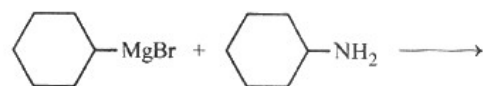

Ans. (4)

73. The correct statement is

- (1) Boron has a maximum covalency of four
- (2) Beryllium has three valence orbitals
- (3) Magnesium has a maximum covalency of four
- (4) Aluminium has five valence orbitals

Ans. (1)

74. A protein undergoes reversible thermal denaturation from its initial state N to denatured state D according to $N \rightleftharpoons D$. At 60°C , the concentrations of both N and D are equal at equilibrium, and the standard enthalpy change of denaturation is 666 kJ mol^{-1} . The standard entropy change (ΔS° in $\text{kJ K}^{-1} \text{ mol}^{-1}$) of the protein upon denaturation at 60°C is closest to

- (1) 2.0
- (2) 2000.0
- (3) 333.0
- (4) 11.1

Ans. (1)

75. Match the species in List I with their geometry in List II

List I	List II
A. PCl_5	I. Tetrahedral
B. BrF_5	II. Square Planar
C. BF_4^-	III. Trigonal bipyramidal
D. $[\text{Ni}(\text{CN})_4]^{2-}$	IV. Square pyramidal

Choose the correct answer from the options given below :

- (1) A - IV, B - III, C - I, D - II
- (2) A - III, B - IV, C - I, D - II
- (3) A - III, B - I, C - II, D - IV
- (4) A - III, B - II, C - I, D - IV

Ans. (2)

76. Given below are two statements :

Statement I :

trans - But - 2 - ene upon treatment with Br_2 in CCl_4 gives the following product

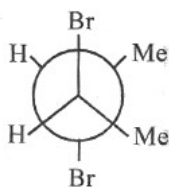

Statement II :

cis - But - 2 - ene upon treatment with alkaline KMnO_4 gives the following product

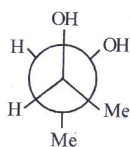

In the light of the above statements, choose the most appropriate answer from the options given below.

- (1) Both statement I and Statement II are correct
- (2) Both Statement I and Statement II are incorrect
- (3) Statement I is correct but Statement II is incorrect
- (4) Statement I is incorrect but Statement II is correct

Ans. (4)

77. Consider the following reaction sequences and choose the correct option.

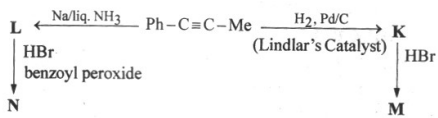

- (1) K and L are geometrical isomers
- (2) K and L are enantiomers
- (3) M and N are geometrical isomers
- (4) M and N are stereoisomers

Ans. (1)

78. The complex which has facial and meridional isomers is

(Given : py = pyridine and en = $\text{H}_2\text{N} - \text{CH}_2 - \text{CH}_2 - \text{NH}_2$)

- (1) $[\text{Cr}(\text{py})_3(\text{Cl})_3]$
- (2) $[\text{Cr}(\text{H}_2\text{O})_6]^{3+}$
- (3) $[\text{Co}(\text{NH}_3)_4(\text{H}_2\text{O})_2]^{3+}$
- (4) $[\text{Ni}(\text{en})_2(\text{H}_2\text{O})_2]^{2+}$

Ans. (1)

79. Identify the reaction which give aniline as the major product.

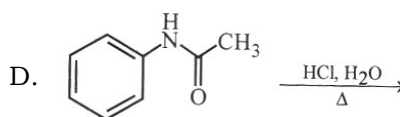
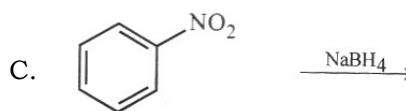
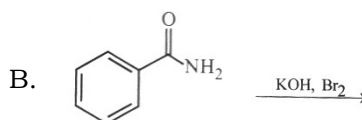
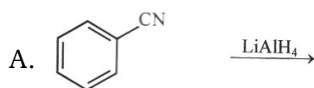

Choose the correct answer from the options given below.

- (1) A and B only
- (2) B and D only
- (3) A and C only
- (4) C and D only

Ans. (2)

80. Match the vitamins the List I with their sources in List II

List I	List II
A. Vitamin A	I. meat
B. vitamin B ₁₂	II. sunflower oil
C. vitamin E	III. green leafy vegetables
D. vitamin K	IV. carrots

Choose the correct answer from the options given below.

- (1) A - II, B - III, C - IV, D - I
- (2) A - IV, B - I, C - II, D - III
- (3) A - IV, B - II, C - I, D - III
- (4) A - III, B - I, C - IV, D - II

Ans. (2)

81. The correct decreasing order of oxidation state of the underlined atom in each molecule is

- (1) $\underline{P}_4O_{10} > \underline{S}O_3 > H_2O$
- (2) $\underline{N}_2O_5 > \underline{Al}_2O_3 > H_2S$
- (3) $\underline{Pb}O_2 > \underline{N}_2O_3 > \underline{S}O_3$
- (4) $\underline{P}_4O_6 > \underline{Cl}_2O_7 > \underline{Al}H_3$

Ans. (2)

82. The compound that Cannot be obtained from the adol condensation reaction shown below, is

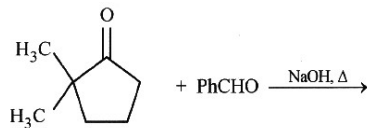

- (1)
- (2)
- (3)
- (4)

Ans. (1)

83. Among the following, the compound having conjugated double bonds is

- (1) hepta - 1, 3 - diene
- (2) hepta - 1, 4 - diene
- (3) hepta - 1, 5 - diene
- (4) hepta - 1, 6 - dinene

Ans. (1)

84. Given below are two statements :

Statement - I : Oxidation of p - nitrotoluene with acidic $KMnO_4$ given an acid that is stronger than benzoic acid.

Statement - II : Reduction of p - nitrotoluene with Sn /HCl followed by neutralization gives an amine that is more basic than aniline.

In light of the above statements, choose the **most appropriate** answer from the options given below.

- (1) Both Statement - I and Statement - II are correct
- (2) Both Statement - I and Statement - II are incorrect
- (3) Statement - I is correct but statement - II is incorrect
- (4) Statement - I is incorrect but Statement - II is correct.

Ans. (1)

85. The green paramagnetic species formed by heating $KMnO_4$ at 513 K is

- (1) K_2MnO_4
- (2) Mn_3O_4
- (3) MnO
- (4) KO_2

Ans. (1)

86. Consider the following reaction, and choose the correct option.

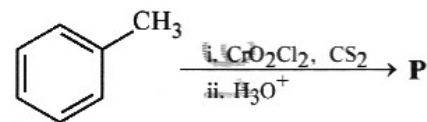

- (1) On treating compound P with saturated $NaHCO_3$ solution, brisk efferevescence is observed
- (2) Compound P can be prepared by treating benzene with anhydrous $AlCl_3$ and CH_3COCl
- (3) On treatment with bromine water, compound P gives a white precipitate
- (4) Compound P is obtained by the hydrogenation of benzoyl chloride with Pd and $BaSO_4$.

Ans. (4)

87. A 1 : 3 electrolyte in an aqueous solution is

- (1) $[CoCl_2(NH_3)_4]Cl$
- (2) $[CoCl(NH_3)_5]Cl_2$
- (3) $[CoCl(NH_3)_6]Cl_3$
- (4) $[Co(NH_3)_3(NO_2)_3]$

Ans. (3)

101. Mad cow disease is caused by
- (1) prions (2) viroids
(3) *Aspergillus sp.* (4) *Mycoplasma sp.*

Ans. (1)

102. Which pigment has absorption peak at 700 nm in the photosynthetic reaction centre PS I (P700)?
- (1) Chlorophyll b (2) Chlorophyll a
(3) Xanthophylls (4) Carotenoids

Ans. (2)

103. In water, frogs respire using _____.
- (1) skin (2) buccal cavity
(3) lungs (4) trachea

Ans. (1)

104. Which of the following represents the correct sequence of arrangement of bones in the lower limb of humans ?
- (1) Femur-tibia-patella-tarsal
(2) Patella-femur-tibia-tarsal
(3) Femur-patella-tibia-tarsal
(4) Femur-tarsal-patella-tibia

Ans. (3)

105. Phyllotaxy is the pattern of arrangement of ____.
- (1) leaves (2) flowers
(3) fruits (4) sepals

Ans. (1)

106. Match List-I with List-II.

List-I		List-II	
A.	Starch	I.	Fights infection
B.	Antibody	II.	Energy storage
C.	Concanavalin A	III.	Glucose transport
D.	Glut-4	IV.	Lectin

Choose the correct answer from the options given below :

- (1) A-I, B-II, C-IV, D-III
(2) A-II, B-I, C-IV, D-III
(3) A-II, B-I, C-III, D-IV
(4) A-I, B-II, C-III, D-IV

Ans. (2)

107. Given below are two statements :

Statement I : When any plane passing through the central axis of the body divides the organism into two identical halves, it is called radial symmetry.

Statement II : In phylum Echinodermata, both adults and larvae are radially symmetrical. In the light of the above statements, choose the most appropriate answer from the options given below :

- (1) Both Statement I and Statement II are correct
(2) Both Statement I and Statement II are incorrect
(3) Statement I is correct but Statement II is incorrect
(4) Statement I is incorrect but Statement II is correct

Ans. (3)

108. Endomembrane system includes _____.

- (1) endoplasmic reticulum, Golgi complex, lysosomes and vacuole
(2) endoplasmic reticulum, chloroplast, peroxisomes and vacuole
(3) mitochondria, chloroplast, peroxisomes and vacuole
(4) Golgi complex, chloroplast, peroxisomes and vacuole

Ans. (1)

109. How many molecules of pyruvic acid are produced at the end of glycolysis from 206 molecules of glucose ?

- (1) 206 (2) 309
(3) 103 (4) 412

Ans. (4)

110. Which of the following plant growth regulators is used as herbicide ?

- (1) 2,4-D (2) Kinetin
(3) Abscisic acid (4) Gibberellin

Ans. (1)

111. Given below are two statements :

Statement I : In gymnosperms, the male and female gametophytes remain within the sporangia.

Statement II : In gymnosperms, seeds are not covered.

In the light of the above statements, choose the most appropriate answer from the options given below :

- (1) Both Statement I and Statement II are correct

119. Arrange the following taxonomic categories in ascending order.

- | | |
|------------|------------|
| a. Genus | b. Class |
| c. Order | d. Phylum |
| e. Family | f. Kingdom |
| g. Species | |

Choose the correct answer from the options given below :

- (1) g, a, e, c, b, d, f
- (2) a, c, d, g, f, b, e
- (3) g, c, d, b, e, a, f
- (4) f, c, b, g, d, e, a

Ans. (1)

120. Match List-I with List-II.

List-I		List-II	
A.	Marginal placentation	I.	<i>Argemone</i>
B.	Axile placentation	II.	Tomato
C.	Parietal placentation	III.	<i>Primrose</i>
D.	Free central placentation	IV.	Pea

Choose the correct answer from the options given below :

- (1) A-II, B-IV, C-I, D-III
- (2) A-IV, B-II, C-III, D-I
- (3) A-IV, B-III, C-I, D-II
- (4) A-IV, B-II, C-I, D-III

Ans. (4)

121. Sphenopsida class belongs to

- | | |
|-----------------|-------------------|
| (1) bryophytes | (2) angiosperms |
| (3) gymnosperms | (4) pteridophytes |

Ans. (4)

122. Which of the following statements regarding photorespiration are correct ?

- (a) Do not occur in C₃ plants
- (b) CO₂ is consumed and O₂ is generated
- (c) Phosphoglycolate is formed
- (d) No synthesis of ATP and NADPH

Choose the correct answer from the options given below :

- (1) (a) and (d) only
- (2) (c) and (d) only
- (3) (b) and (d) only
- (4) (a) and (b) only

Ans. (2)

123. Smooth endoplasmic reticulum _____.

- (1) has ribosomes attached to its surface
- (2) is the major site for the synthesis of lipids
- (3) is actively involved in protein synthesis
- (4) is a site for the synthesis of carbohydrates

Ans. (2)

124. Which one of the following statements is incorrect ?

- (1) α -cells of pancreas secrete glucagon
- (2) α -cells of pancreas secrete insulin
- (3) Glucagon stimulates glycogenolysis
- (4) β -cells of pancreas secrete insulin

Ans. (2)

125. Genus represents _____.

- (1) an individual plant or animal
- (2) a population of plants and animals
- (3) a group of closely related species
- (4) a group of closely related families

Ans. (3)

126. Which of the following is not a prokaryote ?

- | | |
|----------------|----------------------|
| (1) Bacteria | (2) Blue green algae |
| (3) Mycoplasma | (4) Fungi |

Ans. (4)

127. Which of the following plant growth regulators promotes internode elongation prior to flowering in cabbage ?

- | | |
|-------------------------|-----------------|
| (1) Abscisic acid | (2) Gibberellin |
| (3) Indole butyric acid | (4) Ethephon |

Ans. (2)

128. The correct sequence of adult cell cycle phases is _____ .

- | | |
|---|---|
| (1) G ₁ -G ₂ -S-M | (2) G ₁ -M-G ₂ -S |
| (3) G ₁ -S-G ₂ -M | (4) S-M-G ₂ -G ₁ |

Ans. (3)

129. Match List-I with List-II.

List-I		List-II	
A.	Fusion of protoplasts between gametes	I.	Meiosis
B.	Fusion of two nuclei	II.	Plasmogamy
C.	Generation of haploid spores	III.	Karyogamy

Choose the correct answer from the options given below :

- (1) A-II, B-III, C-I (2) A-II, B-I, C-III
 (3) A-III, B-II, C-I (4) A-I, B-III, C-II

Ans. (1)

130. Given below are two statements :

Statement I : The class name Reptilia refers to creeping or crawling mode of locomotion.

Statement II : All organisms belonging to Reptilia have three chambered heart. In the light of the above statements, choose the most appropriate answer from the options given below:

- (1) Both Statement I and Statement II are correct
 (2) Both Statement I and Statement II are incorrect
 (3) Statement I is correct but Statement II is incorrect
 (4) Statement I is incorrect but Statement II is correct

Ans. (3)

131. Given below are two statements :

Statement I : Chromosomes are fully condensed at the end of prophase I.

Statement II : Meiosis I resembles mitosis. In the light of the above statements, choose the most appropriate answer from the options given below :

- (1) Both Statement I and Statement II are true
 (2) Both Statement I and Statement II are false
 (3) Statement I is correct, but Statement II is false
 (4) Statement I is incorrect, but Statement II is true

Ans. (3)

 132. Which of the following is **not** a characteristic of chordates ?

- (1) Presence of notochord
 (2) Central nervous system is dorsal
 (3) Absence of gills
 (4) Presence of post anal part (tail)

Ans. (3)

 133. Length of the stem at time 0 is 20 cm. The arithmetic growth rate is 30 cm per day. What is the length of the stem at the end of the 7th day ?

- (1) 50 cm (2) 170 cm
 (3) 230 cm (4) 460 cm

Ans. (3)

134. Arrange the following elements in descending order of their contribution to percentage weight of the human body.

- a. Oxygen b. Carbon
 c. Hydrogen d. Nitrogen

Choose the correct answer from the options given below :

- (1) a, b, c, d (2) c, a, b, d
 (3) b, c, d, a (4) b, a, c, d

Ans. (1)

135. In frogs, the number of pairs of cranial nerves arising from the brain are _____.

- (1) 6 (2) 9
 (3) 10 (4) 12

Ans. (3)

136. Which of the following is used as a clot buster?

- (1) Streptokinase (2) Penicillin
 (3) cyclosporin A (4) Statins

Ans. (1)

137. The inactive form of Bt toxin is converted to the active form in the insect gut _____.

- (1) due to alkaline pH (2) due to acidic pH
 (3) by proteases (4) by nucleases

Ans. (1)

138. Given below are two statements :

Statement I : Down's syndrome is caused by the absence of one of the x-chromosomes.

Statement II : Turner's syndrome is caused by the presence of an additional copy of the chromosomes.

In the light of the above statements, choose the **correct** answer from the options given below :

- (1) Both **Statement I** and **Statement II** are correct
- (2) Both **Statement I** and **Statement II** are incorrect
- (3) **Statement I** is correct but **statement II** is incorrect
- (4) **Statement I** is incorrect but **Statement II** is correct

Ans. (2)

139. Which of the following disease is **not** sexually transmitted ?

- (1) Syphilis
- (2) Tuberculosis
- (3) Gonorrhoea
- (4) Genital warts

Ans. (2)

140. Sperm motility is due to _____

- (1) flagellar movement
- (2) ciliary movement
- (3) amoeboid movement
- (4) muscular movement

Ans. (1)

141. Natural selection can lead to _____ .

- (a) stabilisation
- (b) genetic drift
- (c) directional change
- (d) disruption

Choose the **correct** answer from the options given below :

- (1) (a) only
- (2) (a), (c) and (d) only
- (3) (a), (b), (c) and (d)
- (4) (a) and (c) only

Ans. (2)

142. The method of directly injecting a sperm into ovum in assisted reproductive technology is called :

- (1) Gamete intra fallopian transfer (GIFT)
- (2) Zygote intra fallopian transfer (ZIFT)

(3) Intra cytoplasmic sperm injection (ICSI)

(4) Embryo transfer (ET)

Ans. (3)

143. Which of the following structure is **not** a part of the male reproductive system ?

- (1) Rete testis
- (2) Epididymis
- (3) Vasa efferentia
- (4) Infundibulum

Ans. (4)

144. Arrange the following in descending order of number of species in the Amazonian rain forest.

- (a) Plants
- (b) Birds
- (c) fishes
- (d) Invertebrates
- (e) Mammals

Choose the **correct** answer from the options given below :

- (1) (c) > (b) > (d) > (e) > (a)
- (2) (d) > (a) > (c) > (b) > (e)
- (3) (e) > (b) > (a) > (c) > (d)
- (4) (b) > (a) > (d) > (c) > (e)

Ans. (2)

145. Given below are two statements :

Statement I : Ovulation is caused by LH surge leading to rupture of Graafian follicles.

Statement II : Graafian follicle remaining after ovulation transform into corpus luteum and secretes large amount of estrogen.

In the light of the above statements, choose the **most appropriate** answer from the options given below :

- (1) Both **Statement I** and **Statement II** are correct.
- (2) Both **Statement I** and **Statement II** are incorrect
- (3) **Statement I** is correct but **Statement II** is incorrect
- (4) **Statement I** is incorrect but **Statement II** is correct

Ans. (3)

146. Which of the following are primary consumers in a food chain ?

- (1) Parasites
- (2) Predators
- (3) Herbivores
- (4) Carnivores

Ans. (3)

147. A population of diploid organisms is at Hardy-Weinberg equilibrium. If the frequency of allele A is 0.1, the frequency of Aa is _____ .
- (1) 0.01 (2) 0.02
(3) 0.10 (4) 0.99

Ans. (1)

148. Match **List - I** with **List - II**.

List - I	List - II
A. Excess growth hormone	I. Reabsorption of water and electrolytes in kidney
B. Luteinizing hormone	II. Contraction of uterus during child birth
C. Vasopressin	III. Acromegaly
D. Oxytocin	IV. Ovulation

Choose the **correct** answer from the options given below :

- (1) A - III, B - IV, C - II, D - I
(2) A - III, B - IV, C - I, D - II
(3) A - II, B - IV, C - I, D - III
(4) A - IV, B - III, C - I, D - II

Ans. (2)

149. The opening between the right atrium and the right ventricle is guarded by _____ .
- (1) bicuspid valve (2) tricuspid valve
(3) semilunar valve (4) sino-atrial node

Ans. (2)

150. Sponges exchange O₂ with CO₂ by _____ .
- (1) simple diffusion over their entire body surfaces
(2) moist cuticle
(3) tracheal tubes
(4) gills

Ans. (1)

151. How many theca are present in each lobe of a typical bilobed angiosperm anther ?
- (1) 2 (2) 6
(3) 8 (4) 12

Ans. (1)

152. Muscle contraction is initiated by a signal sent by the central nervous system by the release of _____
- (1) acetyl choline
(2) acetyl coenzyme A
(3) cycle guanine monophosphate
(4) cycle adenine monophosphate

Ans. (1)

153. Which of the following statements about lac-operon is **correct** ?
- (1) Gene *i* is constitutively expressed
(2) Lactose activates repressor to bind to the operator
(3) Gene *i*, *z*, *y* and *a* share single common promoter
(4) Galactose can act as an inducer of lac operon

Ans. (1)

154. which of the following in female gametophyte of an angiosperm helps in guiding the pollen tube for fertilizing the eggs ?
- (1) Antipodals (2) Synergids
(3) Central cells (4) Polar nucleus

Ans. (2)

155. Which of the following plant produces non-albuminous seeds ?
- (1) Wheat (2) Maize
(3) Barley (4) Pea

Ans. (4)

156. If the diploid chromosome number of typical angiosperm is 36, what would be the chromosome number in its endosperm ?
- (1) 18 (2) 36
(3) 54 (4) 72

Ans. (3)

157. Which of the following statements about the reabsorption process in Henle's loop are **correct**?
- (a) The descending limb of Henle's loop is permeable to water but almost impermeable to electrolytes.
(b) Urine gets concentrated in Henle's loop.
(c) Reabsorption of Na⁺ and water takes place in Henle's loop.
(d) Active or passive transport of electrolytes

occurs in the ascending limb of Henle's loop.

Choose the **correct** answer from the options given below :

- (1) (a) and (b) only (2) (b), (c) and (d) only
 (3) (a), (b) and (c) only (4) (a), (b) and (d) only

Ans. (4)

158. Which of the following is the **correct** order of arrangement of vertebrate column from the head to toe ?

- (1) Cervical vertebra, thoracic vertebra, sacrum, lumbar vertebra
 (2) Sacrum, lumbar vertebra, thoracic vertebra, cervical vertebra
 (3) Cervical vertebra, lumbar vertebra, thoracic vertebra, sacrum
 (4) Cervical vertebra, thoracic vertebra, lumbar vertebra, sacrum

Ans. (4)

159. Which of the following is **not** evidence for evolution ?

- (1) Convergent evolution of traits like wings of bird and butterflies
 (2) Paleontological evidence from fossil records
 (3) Embryological support for evolution as proposed by Ernst Haeckel
 (4) Divergent evolution of anatomical structures such as forelimbs

Ans. (3)

160. Given below are two statements :

Statement I : Modern *Homo sapiens* arose in Australia and moved across continents.

Statement II : *Homo sapiens* arose around 75000 to 10000 years ago.

in the light of the above statements, choose the **most appropriate** answer from the options given below :

- (1) Both **Statement I** and **Statement II** are correct.
 (2) Both **Statement I** and **Statement II** are incorrect.
 (3) **Statement I** is correct but **Statement II** is incorrect.
 (4) **Statement I** is incorrect but **Statement II** is correct.

Ans. (2 & 4)

161. consider a population of 10 million cells. Given the per-capita birth rate of 0.002 (per unit time) and the per-capita death rate of 0.002 (per unit time), the expected number of cells after 10 generations is _____ .

- (1) 1 million (2) 5 million
 (3) 10 million (4) 100 million

Ans. (3)

162. During PCR, primers bind to the DNA strands in the _____ step.

- (1) denaturation (2) extension
 (3) annealing (4) ligation

Ans. (3)

163. Given below are two statements : one is labelled as **Assertion A** and other is labelled as **Reason R**.

Assertion A : The logistic growth model of populations is considered more realistic than the exponential growth model.

Reason R : Resources are finite.

In the light of the above statements, choose the **most appropriate** answer from the options given below :

- (1) Both **A** and **R** are correct and **R** is the correct explanation of **A**
 (2) Both **A** and **R** are correct but **R** is not the correct explanation of **A**
 (3) **A** is correct but **R** is not correct
 (4) **A** is not correct but **R** is correct

Ans. (1)

164. Adaptive radiation in placental mammals and Australian Marsupials leading to similarity between distant species is an example of _____.

- (1) divergent evolution
 (2) convergent evolution
 (3) founder effect
 (4) genetic drift

Ans. (2)

165. Which of the following are secondary lymphoid organs ?

- (a) Bone marrow (b) Tonsils
 (c) Spleen (d) Thymus

Choose the **correct** answer from the options given below :

- (1) (a) and (b) only (2) (b) and (c) only
 (3) (b) and (d) only (4) (a) and (d) only

Ans. (2)

166. Which of the following hormone is **not** secreted by human placenta ?

- (1) hCG (2) Estrogen
(3) Progesterone (4) LH

Ans. (4)

167. Which of the following enzymes synthesizes precursor mRNA ?

- (1) RNA polymerase I
(2) RNA polymerase II
(3) RNA polymerase III
(4) DNA polymerase

Ans. (2)

168. Given below are two statements :

Statement I : Plasmids are autonomously replicating DNA.

Statement II : Plasmids are extrachromosomal DNA.

In the light of the above statements, choose the **most appropriate** answer from the options given below :

- (1) Both **Statement I** and **Statement II** are correct
(2) Both **Statement I** and **Statement II** are incorrect
(3) **Statement I** is correct but **Statement II** is incorrect
(4) **Statement I** is incorrect but **Statement II** is correct

Ans. (1)

169. For a person with blood group 'O', which of the following is **not** a possible combination of parents' blood group genotypes ?

- (1) Father : $I^A i$ and Mother : $I^B i$
(2) Father : $I^A i$ and Mother : $I^A i$
(3) Father : $I^B i$ and Mother : $I^B i$
(4) Father : $I^A I^B$ and Mother : $I^A i$

Ans. (4)

170. Given below are two statements : one is labelled as **Assertion A** and the other is labelled as **Reason R**.

Assertion A : forelimbs of human and bats are homologous.

Reason R : Forelimbs of humans and bats have similar anatomical structure.

In the light of the above statements, choose the **most appropriate** answer from the options given below :

- (1) Both **A** and **R** are correct and **R** is the correct explanation of **A**
(2) Both **A** and **R** are true, but **R** is not the correct explanation of **A**
(3) **A** is true but **R** is false
(4) **A** is false but **R** is true

Ans. (1)

171. Colostrum, secreted by mother during initial days of lactation, is abundant in _____ .

- (1) IgG (2) IgM
(3) IgA (4) IgD

Ans. (3)

172. Given below are two statements : one is labelled as **Assertion A** and the other is labelled as **Reason R**.

Assertion A : Abingdon tortoise in Galapagos islands became extinct within a decade after goats were introduced.

Reason R : Goats were more efficient at browsing than Abingdon tortoise.

In the light of the above statements, choose the **most appropriate** answer from the options given below :

- (1) Both **A** and **R** are correct and **R** is the correct explanation of **A**
(2) Both **A** and **R** are correct but **R** is not the correct explanation of **A**
(3) **A** is correct but **R** is not correct
(4) **A** is not correct but **R** is correct

Ans. (1)

173. The covering of ovum at ovulation is _____ .

- (1) endometrium (2) zona radiata
(3) zona pellucida (4) chorion

Ans. (3)

174. Match **List - I** with **List - II**.

List - I

List - II

- | | |
|---|---|
| A. Both species are harmed
B. One species is harmed and the other is benefited
C. Both species are benefited
D. One is benefited while the other has no effect | I. Predation
II. Mutualism
III. Competition
IV. commensalism |
|---|---|

Choose the **correct** answer from the options given below :

- (1) A - III, B - IV, C - II, D - I
- (2) A - I, B - II, C - III, D - IV
- (3) A - II, B - I, C - IV, D - III
- (4) A - III, B - I, C - II, D - IV

Ans. (4)

175. Given below are two statements : one is labelled as **Assertion A** and the other is labelled as **Reason R**.

Assertion A : In an experiment, Mendel observed that the F₁ progeny plants are all tall and none are dwarf.

Reason R : Stem height is a contrasting trait, with tall being dominant and dwarf being recessive.

In the light of the above statements, choose the **most appropriate** answer from the options given below :

- (1) Both **a** and **R** are correct and **R** is the correct explanation of **A**
- (2) Both **A** and **R** are correct but **R** is not the correct explanation of **A**
- (3) **A** is correct but **R** is not correct
- (4) **A** is not correct but **R** is correct

Ans. (1)

176. Given below are two statements : one is labelled as **Assertion A** and the other is labelled as **Reason R**.

Assertion A : In recombinant DNA technology lysozyme is used for disrupting bacterial cells while cellulase is for plant cells.

Reason R : Isolation of genetic material needs disruption of cells.

In the light of the above statements, choose the **most appropriate** answer from the options given below :

- (1) Both **A** and **R** are correct and **R** is the correct explanation of **A**
- (2) Both **A** and **R** are correct but **R** is not the correct explanation of **A**
- (3) **A** is correct but **R** is not correct
- (4) **A** is not correct but **R** is correct

Ans. (1)

177. Which of the following is used as an effective sedative and painkiller for treating post surgery patients ?

- (1) Interferon
- (2) Antibiotics
- (3) Morphine
- (4) Anti-retroviral drugs

Ans. (3)

178. Which of the following statements are **correct**?

- (a) Energy flow from producers to consumers is unidirectional
- (b) Energy pyramid can never be inverted
- (c) Transfer of energy follows the 1% law

Choose the **correct** answer from the options given below :

- (1) (a), (b) and (c)
- (2) (a) and (b) only
- (3) (a) and (c) only
- (4) (b) and (c) only

Ans. (2)

179. Which of the following statements is **correct** about *Plasmodium* ?

- (1) Reproduces sexually in liver cells
- (2) Reproduces sexually in RBCs
- (3) Gametocytes develop in mosquito gut
- (4) Fertilization takes place in mosquito gut

Ans. (4)

180. Match **List - I** with **List II**.

List - I

List - II

- | | |
|-------------------|-----------------------------------|
| A. Transformation | I. Restriction enzyme |
| B. Cloning site | II. Transfer DNA to host bacteria |
| C. Selection | III. Replication |
| D. Ori | IV. Antibiotic |

Choose the **correct** answer from the options given below :

- (1) A - II, B - I, C - IV, D - III
- (2) A - I, B - II, C - IV, D - III
- (3) A - III, B - IV, C - II, D - I
- (4) A - IV, B - I, C - III, D - II

Ans. (1)

सिर्फ मेडिकल Preparation का संस्थान

शहर एक, संस्थान एक, लेकिन
AIIMS में Selections अनेक



The Legacy of selections in AIIMS continues with BIOME



and many more...

CBSE CLASS XIIth BOARD RESULT 2026

SOME OF OUR TOP PERFORMERS ABOVE 91% IN SCIENCE STREAM

99.2% SHIVANSHI	97.6% AHANA SHOME	97.3% AKANKSHA	96.8% AKSHAT PREM	96.8% SRISHTI PRIYA	96% MRINALINI	95.8% ROHANPREET	95.8% SOUMYA PRATYUSH	95.6% AYUSHMA SHREE
95.6% VED RAJ	95.2% SWASTIKA RAJ	95.2% KRITY	95.2% AREESHA	94.6% SATYAM	94.4% TEJASWI	94.2% PAGOTI KATYAYANI	94.2% NIDHI	
94% SHRUTI SNEHA	93.8% VEDANT	93.6% CHARVI	93.6% VARUN ARYA	93.6% KUMARI ANSHU	93.2% SUHANI	92.8% ANUSHREE	92.8% UJWAL KUMARI	
92.2% PRIYANKA	92.2% SUHANI	92.2% ABHINAV GAURAV	92% CHITRA	91.8% SHAISTA	91.4% SHAURYA RAJ	91.4% TRISHA	91.4% UTKARSHINI	

and many more...

BIOME CLASSROOM HIGHLIGHTS



FOUNDATION (For students moving to Class XI th) New Batches starting from 25th June, 2026	TARGET (For XII th Passed/Dropper Students) New Batches starting from 25th June, 2026	SCHOLARSHIP CUM ADMISSION TEST (For NEET 2027/2028) Test Date 20th & 21st June, 2026 22nd & 23rd June, 2026	SCAN & REGISTER FOR B-SAT
---	--	--	--------------------------------------